

# GM 10

## Submersible Drainage Pump



### Construction

Submersible drainage pump constructed with composite polymers developed especially for this product.

These new rustproof materials are resistant to corrosion, indeformable at maximum temperature differentials in the pump and motor and resistant to internal and external strain.

Shaft of chrome steel AISI 430. Three lip seals in NBR.

With float switch for automatic start/stop.

### Applications

For clean or slightly dirty water.

For draining flooded rooms or tanks.

Extraction of water from ponds, flowing water or pits for collection of rain water. For irrigation purposes.

For use outdoor, the power supply cable shall have a length not less than 10 m.

### Operating conditions

Maximum liquid temperature for prolonged use: 35 °C (with immersed motor).

Immersion depth: 5 m max (with suitable cable length).

Not suitable for continuous duty for prolonged time.

### Motor

2-pole induction motor, 50 Hz ( $n \approx 2900$  rpm).

Single-phase 230 V  $\pm 10\%$ , with thermal protector.

Capacitor inserted in the housing incorporated in the plug.

Cable: with plug, length 5 m, 245IEC57 4 G 0,75 mm<sup>2</sup>, according to EN 60335-2-41 for pumps up to 5 kg.

Insulation class B.

Protection IP X8.

Triple impregnation humidity-proof dry winding.

### Special features on request

Other voltages.

Frequency 60 Hz (as per 60 Hz data sheet).

Cable H07RN8-F, 4 G 1 mm<sup>2</sup>, length 10 m, without plug.

Control box with capacitor, for pumps with cable without plug.

Without float switch.

With elbow on discharge port.

### Characteristic curve and performance $n \approx 2900$ rpm

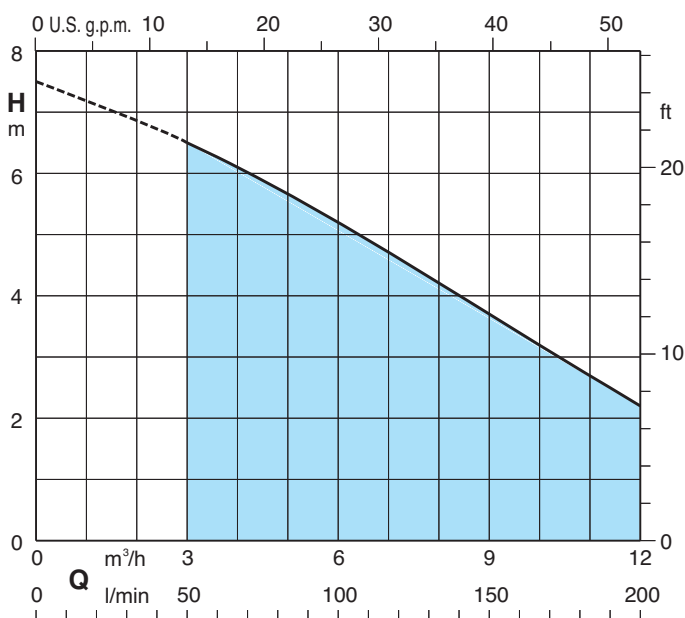

1~	230V	Capacitor			P1	P2			m <sup>3</sup> /h Q l/min	0	3	6	9	12
		A	μF	V		kW	kW	HP		0	50	100	150	200
<b>GM 10</b>		1,75	6,3	450	0,4	0,3	0,4	<b>H m</b>	7,5	6,5	5,2	3,7	2,2	

P1 Max. power input

P2 Rated motor power output

H Total head in m

### Dimensions and weights

Weight kg 5

Control box (on request)

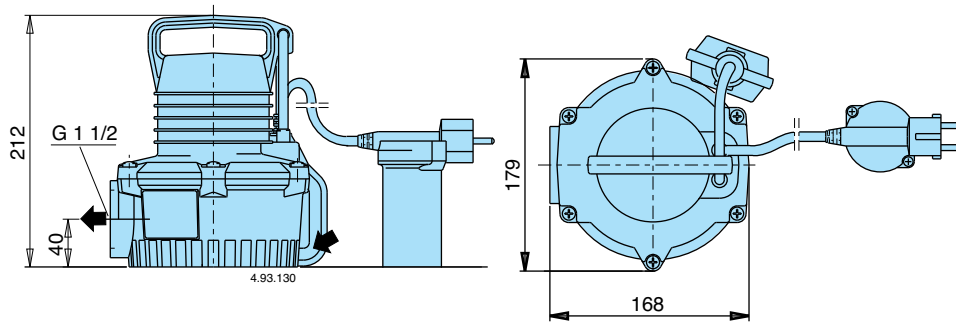

Type	Capacitor	Weight
QM 10	6,3 $\mu$ F 450 V	0,4 kg

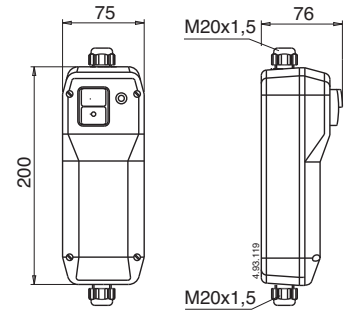

### Installation examples

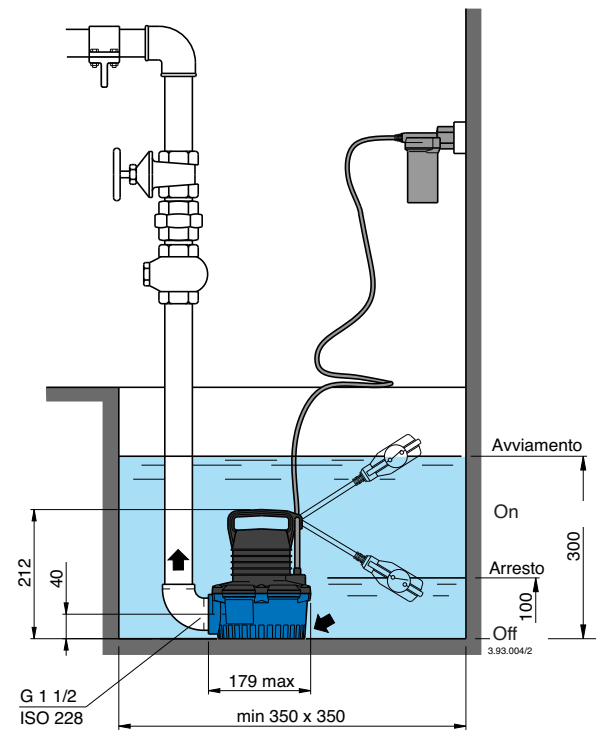

### Low cost installation

Immersed without suction pipe and valve. No filling operations at start-up, no suction problems and greater safety against running dry.

### Features

#### Maximum reliability

A metal support ensures correct alignment between the pump shaft and the motor also in heavy duty conditions.

A threaded metallic insert in the delivery port allows for secure connection of the delivery pipe or fitting without any risk of damaging the pump.

A suction strainer prevents solids bigger than 8 mm grain size from entering the pump.

#### Compact

Minimum dimension and high levels of performance, for use in many different applications, for flow rates up to 200 liters/min.

